

# PCschematic® PowerDistribution

## Instant registration of distribution networks

The new program PCschematic PowerDistribution turns registration of the connectivity in electrical supply networks into a simple task. By applying the techniques from Windows Explorer, maintenance of the registration becomes a question of few minutes work.

When for instance a new factory has been constructed and all the machinery have been installed, a complete technical drawing of the installation is typically produced.

But already the first time you need to move a machine to make room for a another, the survey starts fading.

Normally because time for keeping the documentation up-to-date in the daily maintenance have not been scheduled. And this disorder increases for every single change in the production line.

” PCschematic Power-Distribution can be applied to registrate any kind of distribution networks. This article focuses on how to use the program for registering power distribution.”

Therefore you typically end up in a situation where no-one has a complete survey, and changes in the production line and maintenance becomes unnecessary complicated and expensive for the company.

### Lack of survey is expensive

If you do not have a survey of the power distribution, a considerable part of the working hours will be spend like this:

- Following cables through the factory to find out where the power can be disconnected
- During changes you will have to stop too much of the production
- Too much time is spent discovering where new machines can be connected, and whereto the old machines can be moved
- Unnecessarily long initiation period for new employees - and for hired consultants
- Uncertainty whether the power is disconnected the right place

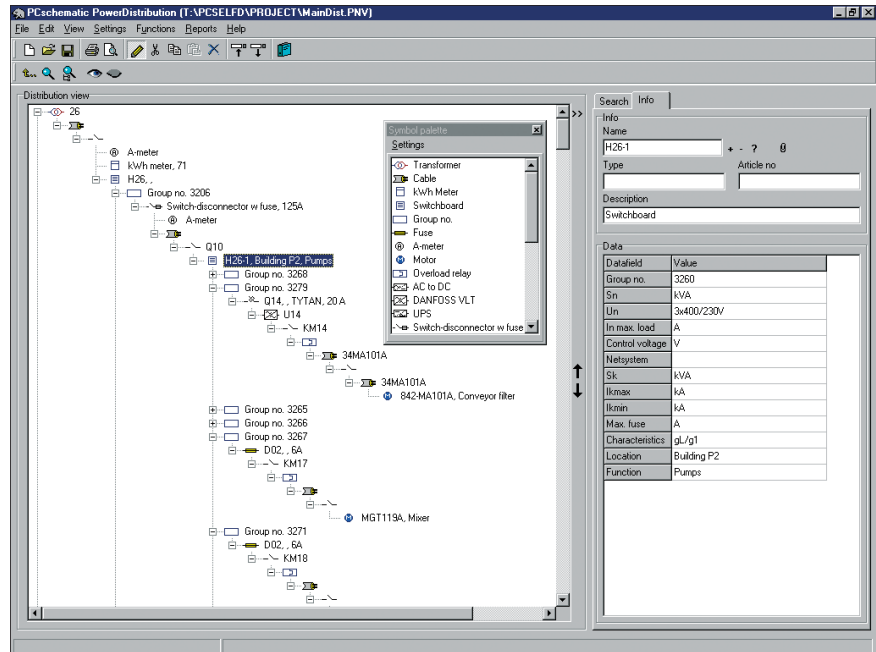

Using PCschematic PowerDistribution you can maintain the complete registration of the power distribution network in few minutes

- Lack of sharing of knowledge for instance when working in shifts, when using temporary employees etc.

In other words: Lack of survey means that repairs and rearrangements in the production becomes unnecessarily complex and time consuming.

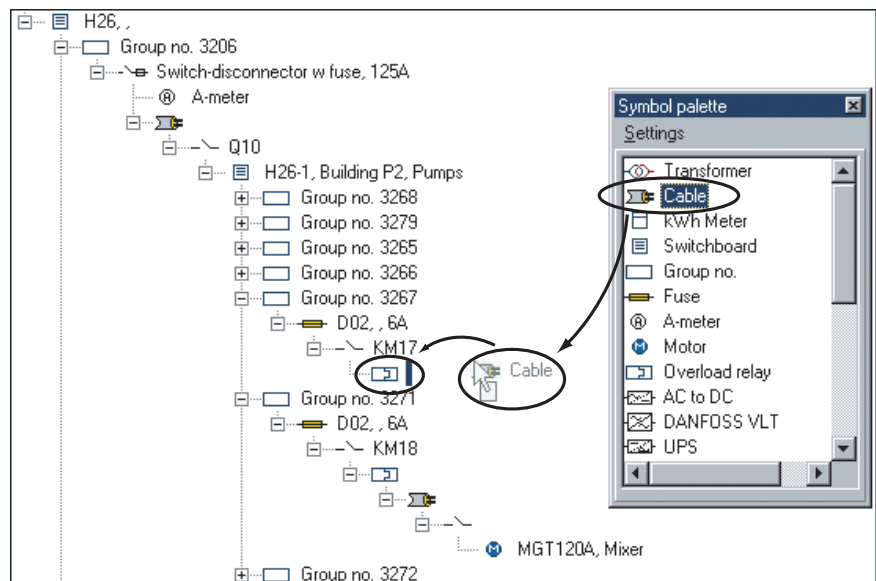

When registering a cable, you just drag a cable symbol from the symbol palette to its position in the registration - just like you move a folder in Windows Explorer: Article data can be attached to the components when necessary.

## The registration can now be done in few minutes

However, it is not so strange that the survey over most power supply networks have been lacking: Up till recently it has been both time-consuming and complicated to register it. And it has in particular required too many resources to maintain the created registration.

With the introduction of the program PCschematic PowerDistribution, it has now become possible to maintain the survey in a quick and simple way.

The basic concept of the program is that you to a start just have to spend a few minutes *registering* - not documenting - the connectivity of the components in the power distribution network.

You can then at a later stage add more detailed documentation.

” Anybody having tried to move a folder in Windows Explorer, can grasp the basic concept of this program in few minutes.”

This makes it easy to maintain the survey even under stressed working conditions.

## The program is easily learned

The registration of the connectivity in electrical power distribution networks is done in the easiest way possible.

Anybody who has tried working in Windows, and have tried to move a folder in the Windows Explorer, can grasp the basic concept in few minutes.

The next step is to start registering right away.

## Just like moving folders in Windows Explorer

When you register the power supply in for instance a factory, the program displays a survey window and a palette containing symbols for the various components in the supply net - please refer to the previous page.

When for instance you wish to register a transformer, you *drag* a transformer symbol from the palette to the distribution window in the program.

If you then wish to register a cable going out from the transformer, you drag a cable symbol from the palette, and place it under the transformer symbol. Exactly like you would place one folder under another in Windows Explorer.

This way you can continue dragging symbols to the distribution window, until the entire installation is registered. The folder-hierarchy thus mirrors the overall structure in the electrical supply network.

On the level below the transformer, you could for instance register the five cables going out from the transformer.

On the level below each of these cables the loads and distribution panels they are connected to are displayed - etc.

The symbols in the symbol palette can be adapted to contain the exact symbols needed for each individual company, and different palettes for different purposes can be created.

## Changes can be documented instantly

One of the most remarkable features is how quickly you can document changes in the registration.

When for instance you have moved a machine, you just drag the symbol for the machine to below the distribution panel where it is now connected - just like moving a folder in Windows. And the registration is updated. That is all you have to do.

Everything belonging to the machine - like the contents of a folder - is also moved automatically.

## Attaching data to the components

If you attach data to the components you can also get a survey of the load in

the system. You can then see on which distribution panel it is most appropriate to attach your new machines - and see where it is most appropriate to move the old machines to.

You can freely define which types of data you wish to attach to the different symbols/components.

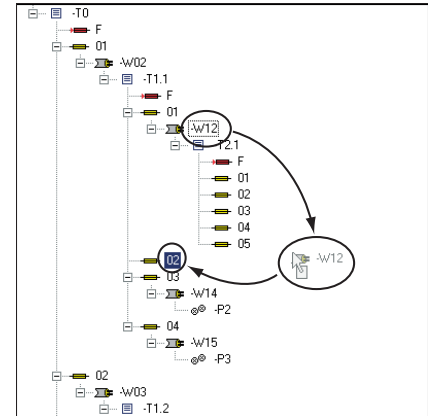

*When you move a cable - or for instance a machine - you just drag it to its new position, and the registration is updated*

## Calculations on data

Having typed in calculation data, you can furthermore apply various mathematical functions - such as sine, cosine, arctangent, addition, subtraction, multiplication and division - for calculations.

## Survey of the power distribution

When you have made a complete registration of the electrical supply net, you

**low rating busbar trunking systems**  
distribution type, from 40 to 100A  
specifications

**1. general**

- the busbar trunking system shall comply with the International IEC 60439-2 standard and the European EN 60439-2 standard
- the busbar trunking system shall have a rated insulation voltage of 500 V
- the busbar trunking system shall have a rated short-circuit current of 25 kA for 1 s
- the busbar trunking system shall have a rated operating voltage of 24 to 250 V rms
- the busbar trunking system shall have a maximum number of poles of 4 for the 40 A and 63 A ratings and 16 for the 100 A rating
- the 40 to 100 A busbar trunking systems shall have a degree of protection of IP20 for the working conditions

**2. construction and operation**

- the busbar trunking system shall include 2 active conductors. The length of the straight sections of the busbar trunking system shall be 2 to 3 meters. A sub-bus or additional rail may be used to run cables parallel with the busbar, by means of specially designed mounting
- the casing shall be made of non-flammable material and shall act as the protective earth conductor (PE)
- the busbar trunking system shall be equipped with a locking device for the doors, which shall be opened and closed by means of a special key
- mechanical protection between two sections of busbar trunking system shall be provided by means of specially designed mounting
- the mounting brackets shall be designed to meet the requirements of the standard
- the busbar trunking system shall be supplied to all an
- the top off key down shall be fixed with a lock with the earth. The key shall be inserted in the lock
- the 40 to 100 A busbar trunking system shall be equipped with a locking device for the doors, which shall be opened and closed by means of a special key
- the busbar trunking system shall be supplied to all an
- the top off key down shall be fixed with a lock with the earth. The key shall be inserted in the lock
- the 40 to 100 A busbar trunking system shall be equipped with a locking device for the doors, which shall be opened and closed by means of a special key
- the busbar trunking system shall be supplied to all an
- the top off key down shall be fixed with a lock with the earth. The key shall be inserted in the lock

**3. protection and safety**

- the busbar trunking system shall comply with the requirements of the standard
- the top off key down shall be fixed with a lock with the earth. The key shall be inserted in the lock
- the 40 to 100 A busbar trunking system shall be equipped with a locking device for the doors, which shall be opened and closed by means of a special key
- the busbar trunking system shall be supplied to all an
- the top off key down shall be fixed with a lock with the earth. The key shall be inserted in the lock

*To the components in the registration you can attach documents from other programs, such as Word, Acrobat, AutoCAD and PCschematic ELautomation*

can work faster and more precisely when reorganizing the production and in the daily maintenance.

You can now go in and disconnect the current exactly where necessary. Nobody risks their lives by disconnecting the wrong fuse, and you only have to stop the smallest part possible of the production.

### Attach other documents to the components

To the individual components in the registration, you can attach documents from other computer programs.

This being for instance technical specifications for a cable tray, which you have documented in a Word document or a pdf file. Or maybe an AutoCAD document - etc.

If you have installed PCschematic ELautomation - or a PCschematic Viewer - you can furthermore open electro-technical documentation projects directly from PCschematic PowerDistribution.

### Survey of all attached documents

Thus you can use the structure created by PCschematic PowerDistribution to keep track of all documents attached to the installation.

These documents does not necessarily have to be placed in pre-defined folders, because they can just be opened via links from PCschematic PowerDistribution.

### Registration reports

In PCschematic PowerDistribution you can also print out registration reports, in order to get the survey on paper. The report can also be generated as a PC-schematic ELautomation project, or as a set of graphical files for insertion in other documentation.

### Search system for Components

The program furthermore contains a search system for components, where you can search for the component names, descriptions, locations - or other data.

This way you can quickly locate for instance specific motors or distribution panels.

### Register the information on the PC right away

If for instance you are working as a consultant, and your task is to maintain a production line in a factory, you have to ask a lot of questions to achieve the necessary degree of survey.

Returning three months later - having worked lots of other places in the meantime - you can hardly avoid to ask part of the same questions again.

Having PCschematic PowerDistribution on a transportable PC, you can save lots of time and trouble by registering the necessary information the same minute you get it.

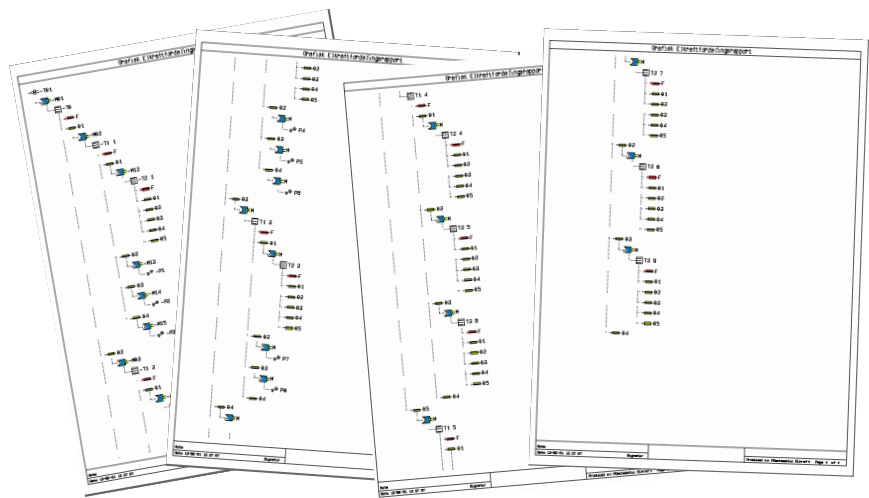

*When the registration is created you can print it - or create a PCschematic ELautomation document or a graphical file of the registration*